

1) Sensing surface, 2) Housing, 3) Cover, 4) Power indicator green, 5) Function indicator yellow



Basic features

Approval/Conformity	cULus CE UKCA WEEE
Basic standard	IEC 60947-5-2
Scope of delivery	Holder Installation guide
Sensitivity	Switching distance teachable
Series	R08
Trademark	Global

Display/Operation

Function indicator	yes
Power indicator	yes
Setting	Teachable

Electrical connection

Cable diameter D	3.40 mm
Cable length L	2 m
Conductor cross-section	0.14 mm ²
Number of conductors	4
Polarity reversal protected	yes
Protection against device mix-ups	yes
Short-circuit protection	yes

Electrical data

Load capacitance max. at Ue	0.33 µF
No-load current I _o max. at Ue	12.5 mA
Operating voltage U _b	12...30 VDC
Rated insulation voltage U _i	75 V DC
Rated operating current I _e	50 mA
Rated operating voltage U _e DC	24 V
Ready delay t _v max.	200 ms
Residual current I _r max.	10 µA
Ripple max. (% of U _e)	10 %
Switching frequency	50 Hz
Utilization category	DC -13
Voltage drop static max.	1.5 V

Environmental conditions

Ambient temperature	-25...70 °C
Contamination scale	1
IP rating	IP67

Functional safety

MTTF (40 °C)	98 a
--------------	------

Interface

Switching output	NPN normally closed (NC)
------------------	--------------------------

Capacitive Sensors
BCS R08RRE-NOM80C-EP02
Order Code: BCS012F



Material

Cover material	PP
Housing material	PP
Material jacket	PUR
Material sensing surface	PP

Range/Distance

Hysteresis H max. (% of Sr)	20.0 %
Measuring range	1...8 mm
Real switching distance sr	8 mm
Repeat accuracy max. (% of Sr)	5.0 %
Temperature drift max. (% of Sr)	20 % [-5...55 °C]

Mechanical data

Dimension	34 x 16 x 8 mm
Installation	for flush mounting
Size	Block style
Tightening torque	0.2 Nm

Remarks

For full calibration connect input DI to L+ for 2...7 seconds. For empty calibration connect to L+ for 7..12 seconds.
 Input DI can be used for teaching the switching point. In normal operation input DI should be connected continuously to L-.
 The potentiometer does not have a fixed stop, but can be turned endlessly without destroying anything.
 If no change in the switching signal is detected, the potentiometer should be turned forwards or backwards until a signal change occurs at the output.
 For more information about MTTF and B10d see MTTF / B10d Certificate

Indication of the MTTF- / B10d value does not represent a binding composition and/or life expectancy assurance; these are simply experiential values with no warranty implications. These declared values also do not extend the expiration period for defect claims or affect it in any way.

Wiring Diagrams

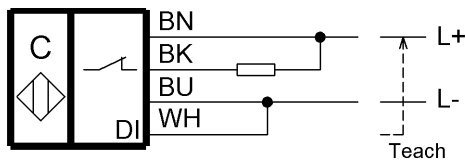

Help Views

Zubehör - Halter
Accessories - Mounting frame

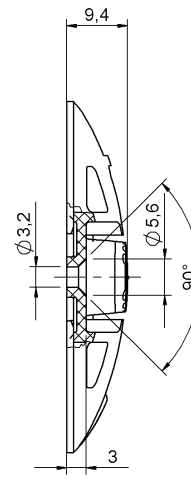
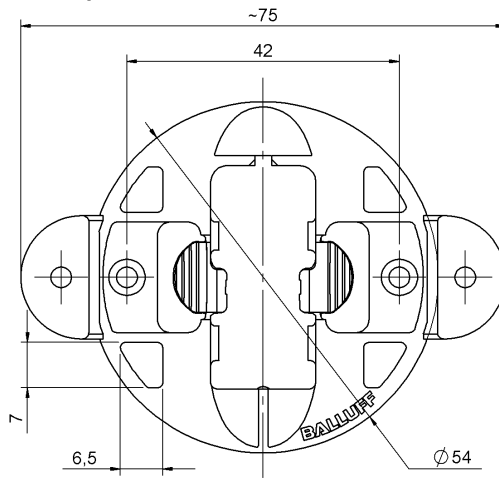

Werkstoff Halter: PP
Material mounting frame: PP